

TICC/SS

EDIBON PATENT
Teaching Technique used

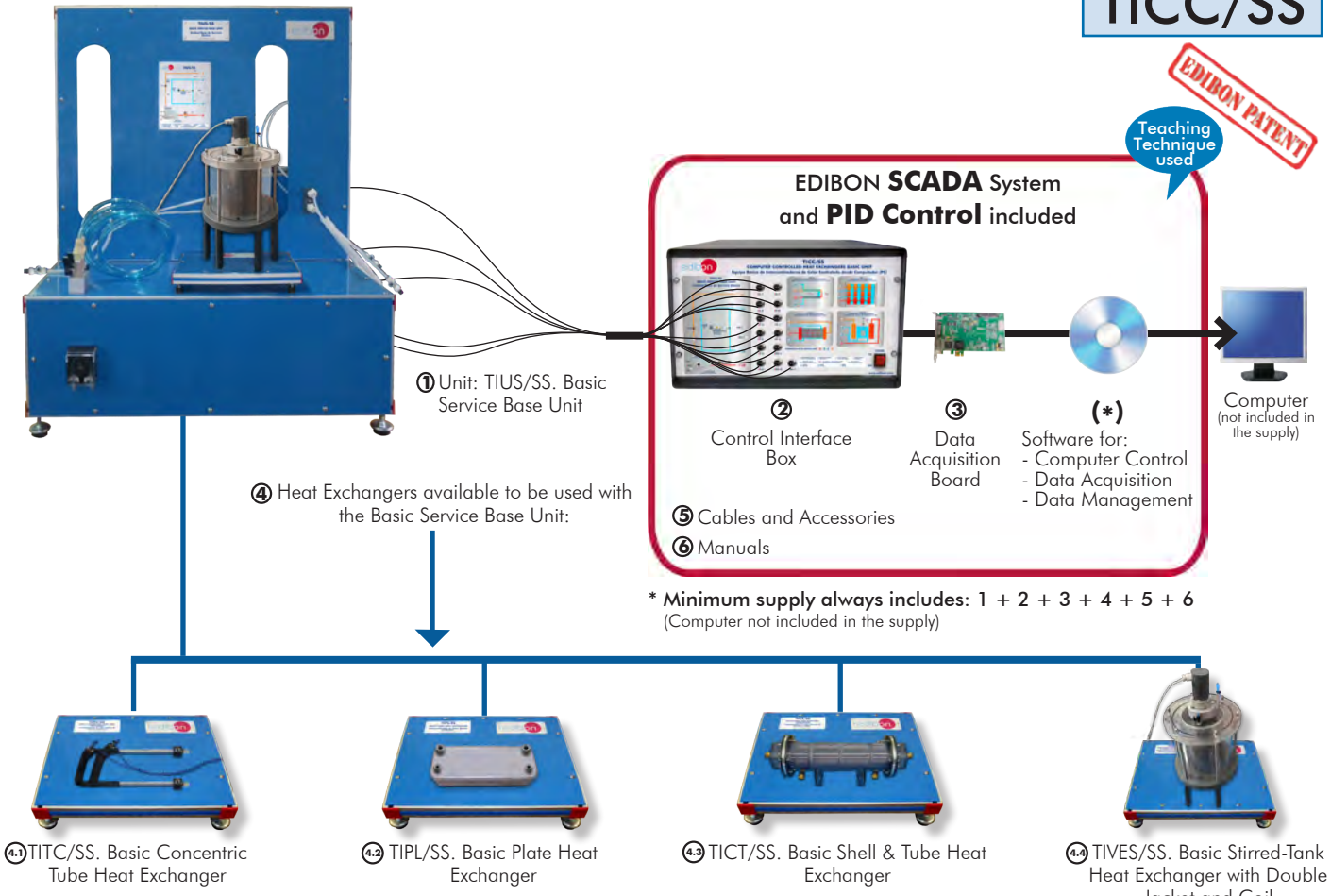

Key features:

- > **Advanced Real-Time SCADA and PID Control.**
- > **Open Control + Multicontrol + Real-Time Control.**
- > **Specialized EDIBON Control Software based on LabVIEW.**
- > **National Instruments Data Acquisition board (250 KS/s, kilo samples per second).**
- > **Calibration exercises, which are included, teach the user how to calibrate a sensor and the importance of checking the accuracy of the sensors before taking measurements.**
- > **Projector and/or electronic whiteboard compatibility allows the unit to be explained and demonstrated to an entire class at one time.**
- > **Capable of doing applied research, real industrial simulation, training courses, etc.**
- > **Remote operation and control by the user and remote control for EDIBON technical support, are always included.**
- > **Totally safe, utilizing 4 safety systems (Mechanical, Electrical, Electronic & Software).**
- > **Designed and manufactured under several quality standards.**
- > **Optional ICAI software to create, edit and carry out practical exercises, tests, exams, calculations, etc. Apart from monitoring user's knowledge and progress reached.**
- > **This unit has been designed for future expansion and integration. A common expansion is the EDIBON Scada-Net (ESN) System which enables multiple students to simultaneously operate many units in a network.**

**OPEN CONTROL
+
MULTICONTROL
+
REAL TIME CONTROL**



www.edibon.com
PRODUCTS
↳ 90+ THERMODYNAMICS & THERMOTECHNICS

For more information about Key Features, click here



ISO 9001: Quality Management (for Design, Manufacturing, Commercialization and After-sales service)



European Union Certificate (total safety)



Certificates ISO 14001 and ECO-Management and Audit Scheme (environmental management)



Certificate and Worlddidac Member

INTRODUCTION

The heat exchange process between two fluids at different temperature and separated by a solid wall is performed in devices named heat exchangers.

Heat exchangers are widely used in refrigeration, air conditioning, heating, energy generation, chemical processing, etc. They have many applications in engineering and, as a consequence, there are many models adapted to each application to obtain an efficient heat transfer.

GENERAL DESCRIPTION

The Computer Controlled Basic Heat Exchangers Unit (TICC/SS) has been designed by Edibon to study and compare different types of small-scale heat exchangers working with parallel or counterflow arrangements.

The complete unit consists of two main elements: the service base unit and a heat exchanger.

The Basic Service Base Unit (TIUS/SS) is common for the optional "/SS" type heat exchangers. Its functions are:

- Heating water in a computer controlled thermostatic bath.
- Pumping the hot water.
- Regulation and measurement of the cold water and hot water flows.
- Measurement of the inlet and outlet temperatures of the cold water and the hot water.
- Measurement of the pressure drop in the exchanger.

To supply cold water there are two options: tap water or our recommended element, the Refrigeration Water Recirculation Unit "TERA".

The optional heat exchangers are:

- TITC/SS, Basic Concentric Tube Heat Exchanger. It has been designed to study the heat transfer between hot water flowing through an internal tube and cold water flowing through the annular area between the internal and the external tubes.
- TIPL/SS, Basic Plate Heat Exchanger. It has been designed to study the heat transfer between hot water and cold water flowing through alternate channels formed between parallel plates.
- TICT/SS, Basic Shell and Tube Heat Exchanger. It consists of a series of tubes inside the heat exchanger where hot water flows. The cooling water flows through the space between the inner tubes and the shell. There are baffles located across the shell to direct the cold water flow and increase the heat transfer.
- TIVES/SS, Basic Stirred-tank heat exchanger with double jacket and coil. It has been designed to study the heat transfer between the hot water that flows through a jacket or coil and the cold water contained in the stirred tank.

This Computer Controlled Unit is supplied with the EDIBON Computer Control System (SCADA), and includes: The unit itself + a Control Interface Box + a Data Acquisition Board + Computer Control, Data Acquisition and Data Management Software Packages, for controlling the process and all parameters involved in the process.

4 actuators and 12 sensors controlled from any computer, and working simultaneously

OPEN CONTROL
+
MULTICONTROL
+
REAL TIME CONTROL

TIUS/SS

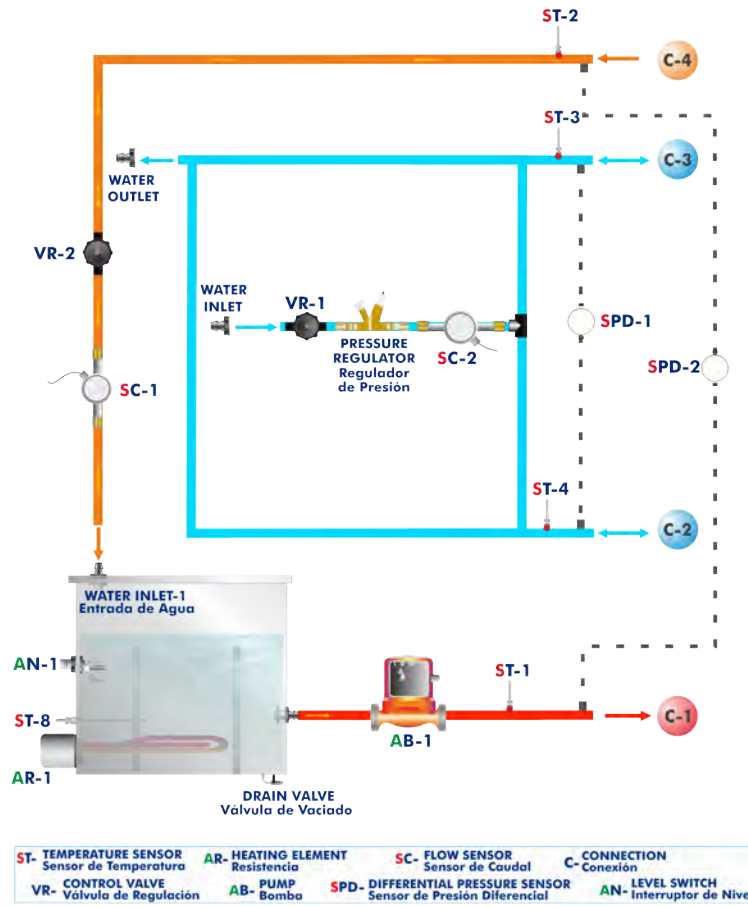

TITC/SS

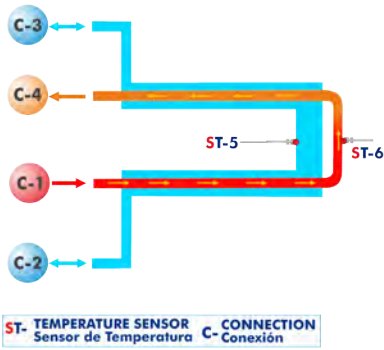

TICT/SS

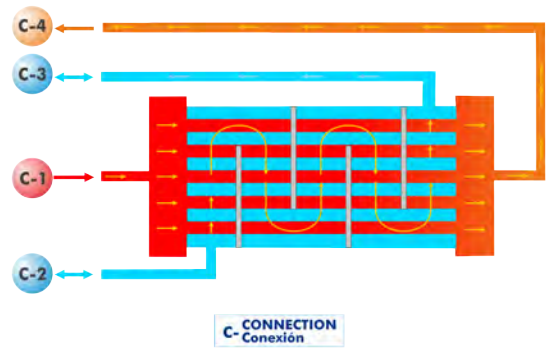

TIVES/SS

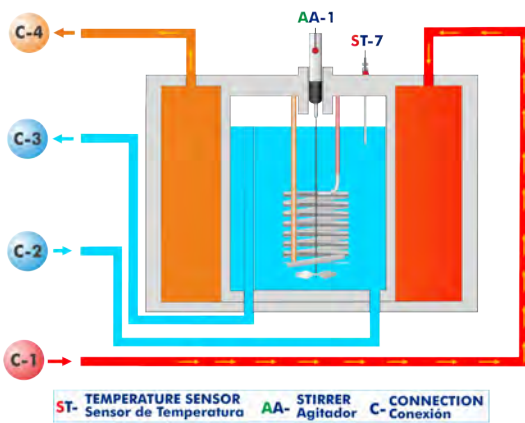

TIPL/SS

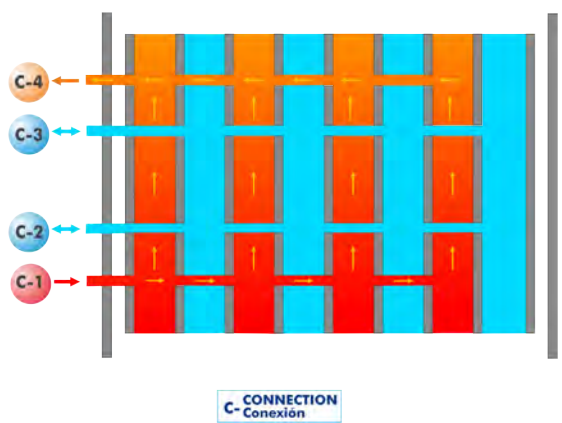

With this unit there are several options and possibilities:

- Main items: 1, 2, 3, 4, 5 and 6.
- Optional items: 7, 8, 9, 10 and 11.

Let us describe first the main items (1 to 6):

① **TIUS/SS. Base Basic Service Unit:**

Basic Service Base Unit

Anodized aluminum frame and panel made of painted steel.

Main metallic elements made of stainless steel.

Diagram in the front panel with distribution of the elements similar to the real one.

Stainless steel tank (10 l), equipped with:

Computer controlled electric heating element (3000 W) with thermostat (70 °C) to heat water.

PID temperature control.

Temperature sensor ("J" type) to measure the water temperature.

Level switch to control the water level in the tank.

Stainless steel cover to avoid contact with hot water. The cover has a hole to visualize the water level and to fill the tank.

Water drain valve.

Centrifugal pump with speed control from computer, range: 0 - 3 l/min.

Two flow sensors, one for hot water and the other for cold water, range: 0.25 - 6.5 l/min.

Two differential pressure sensors to measure the pressure drop in each exchanger.

Four "J" type temperature sensors to measure the inlet and outlet temperatures.

Control valves for cold and hot water.

Pressure regulator to prevent excess pressure in the exchangers, set to 0.6 bar.

Quick release fittings to connect the exchangers.

The complete unit includes as well:

Advanced Real-Time SCADA and PID Control.

Open Control + Multicontrol + Real-Time Control.

Specialized EDIBON Control Software based on LabVIEW.

National Instruments Data Acquisition board (250 KS/s, kilo samples per second).

Calibration exercises, which are included, teach the user how to calibrate a sensor and the importance of checking the accuracy of the sensors before taking measurements.

Projector and/or electronic whiteboard compatibility allows the unit to be explained and demonstrated to an entire class at one time.

Capable of doing applied research, real industrial simulation, training courses, etc.

Remote operation and control by the user and remote control for EDIBON technical support, are always included.

Totally safe, utilizing 4 safety systems (Mechanical, Electrical, Electronic & Software).

Designed and manufactured under several quality standards.

Optional ICAI software to create, edit and carry out practical exercises, tests, exams, calculations, etc. Apart from monitoring user's knowledge and progress reached.

This unit has been designed for future expansion and integration. A common expansion is the EDIBON Scada-Net (ESN) System which enables multiple students to simultaneously operate many units in a network.



Unit: TIUS/SS

② TICC/SS/CIB. Control Interface Box:

The Control Interface Box is part of the SCADA system.

Control interface box with process diagram in the front panel and with the same distribution that the different elements located in the unit, for an easy understanding by the student.

All sensors, with their respective signals, are properly manipulated from -10V to +10V computer output.

Sensors connectors in the interface have different pines numbers (from 2 to 16), to avoid connection errors.

Single cable between the control interface box and computer.

The unit control elements are permanently computer controlled, without necessity of changes or connections during the whole process test procedure.

Simultaneous visualization in the computer of all parameters involved in the process.

Calibration of all sensors involved in the process.

Real time curves representation about system responses.

Storage of all the process data and results in a file.

Graphic representation, in real time, of all the process/system responses.

All the actuators' values can be changed at any time from the keyboard allowing the analysis about curves and responses of the whole process.

All the actuators and sensors values and their responses are displayed on only one screen in the computer.

Shield and filtered signals to avoid external interferences.

Real time PID control with flexibility of modifications from the computer keyboard of the PID parameters, at any moment during the process.

Real time PID and on/off control for pumps, compressors, heating elements, control valves, etc.

Real time PID control for parameters involved in the process simultaneously.

Proportional control, integral control and derivative control, based on the real PID mathematical formula, by changing the values, at any time, of the three control constants (proportional, integral and derivative constants).

Open control allowing modifications, at any moment and in real time, of parameters involved in the process simultaneously.

Possibility of automatization of the actuators involved in the process.

Three safety levels, one mechanical in the unit, another electronic in the control interface and the third one in the control software.

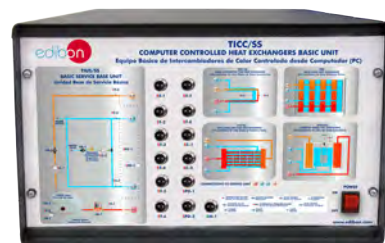

TICC/SS/CIB

③ DAB. Data Acquisition Board:

The Data Acquisition board is part of the SCADA system.

PCI Express Data acquisition board (National Instruments) to be placed in a computer slot. Bus PCI Express.

Analog input:

Number of **channels= 16** single-ended or 8 differential. **Resolution= 16 bits**, 1 in 65536.

Sampling rate up to: 250 KS/s (kilo samples per second).

Input range (V)= ± 10 V. Data transfers=DMA, interrupts, programmed I/O. DMA channels=6.

Analog output:

Number of **channels=2**. **Resolution= 16 bits**, 1 in 65536.

Maximum output rate up to: 900 KS/s.

Output range(V)= ± 10 V. Data transfers=DMA, interrupts, programmed I/O.

Digital Input/Output:

Number of **channels=24 inputs/outputs**. D0 or DI Sample Clock frequency: 0 to 100 MHz.

Timing: Number of **Counter/timers=4**. Resolution: Counter/timers: 32 bits.



DAB

④ **Heat Exchangers available** to be used with the Basic Service Base Unit:

④.1 **TITC/SS. Basic Concentric Tube Heat Exchanger.**

Panel made of painted steel.

Diagram in the front panel with distribution of the elements similar to the real one.

The exchanger is composed of two concentric tubes.

Hot water flows through the inner tube and cold water flows through the space between the inner and outer tubes.

Operation with parallel and countercurrent flow.

Heat transfer area: 0.025 m².

Inner tube made of stainless Steel:

External diameter: 12 mm.

Thickness = 1 mm.

Outer tube made of PMMA:

External diameter: 20 mm.

Thickness = 2 mm.

Two temperature sensors "J" type to measure the temperature in the middle of the transfer section.

Quick release fittings to connect the exchanger to the service base unit.

This unit is supplied with 8 manuals: Required Services, Assembly and Installation, Interface and Control Software, Starting-up, Safety, Maintenance, Calibration & Practices Manuals.

Computer Control Software:

PID Computer Control + Data Acquisition + Data Management Software for Basic Heat Exchanger of Concentric Tubes (TITC/SS).

The three softwares are part of the SCADA system.

Compatible with actual Windows operating systems. Graphic and intuitive simulation of the process in screen. **Compatible with the industry standards.**

Registration and visualization of all process variables in an automatic and simultaneous way.

Flexible, open and multicontrol software, developed with actual windows graphic systems, acting simultaneously on all process parameters.

Analog and digital PID control.

PID menu and set point selection required in the whole work range.

Management, processing, comparison and storage of data.

Sampling velocity up to 250 KS/s (kilo samples per second).

Calibration system for the sensors involved in the process.

It allows the registration of the alarms state and the graphic representation in real time.

Comparative analysis of the obtained data, after the process and modification of the conditions during the process.

Open software, allowing the teacher to modify texts, instructions. Teacher's and student's passwords to facilitate the teacher's control on the student, and allowing the access to different work levels.

This unit allows the 30 students of the classroom to visualize simultaneously all the results and the manipulation of the unit, during the process, by using a projector or an electronic whiteboard.



TITC/SS



④ **Heat Exchangers available** to be used with the Basic Service Base Unit:

④.2 **TIPL/SS. Basic Plate Heat Exchanger.**

Panel made of painted steel.

Diagram in the front panel with distribution of the elements similar to the real one.

Formed by corrugated stainless steel plates.

Number of plates: 6.

Heat transfer area: 0.05 m².

Quick release fittings to connect the exchanger to the service base unit.

This unit is supplied with 8 manuals: Required Services, Assembly and Installation, Interface and Control Software, Starting-up, Safety, Maintenance, Calibration & Practices Manuals.



TIPL/SS

Computer Control Software:

PID Computer Control + Data Acquisition + Data Management Software for Basic Plate Heat Exchanger (TIPL/SS).

The three softwares are part of the SCADA system.

Compatible with actual Windows operating systems. Graphic and intuitive simulation of the process in screen. **Compatible with the industry standards.**

Registration and visualization of all process variables in an automatic and simultaneous way.

Flexible, open and multicontrol software, developed with actual windows graphic systems, acting simultaneously on all process parameters.

Analog and digital PID control.

PID menu and set point selection required in the whole work range.

Management, processing, comparison and storage of data.

Sampling velocity up to 250 KS/s (kilo samples per second).

Calibration system for the sensors involved in the process.

It allows the registration of the alarms state and the graphic representation in real time.

Comparative analysis of the obtained data, after the process and modification of the conditions during the process.

Open software, allowing the teacher to modify texts, instructions. Teacher's and student's passwords to facilitate the teacher's control on the student, and allowing the access to different work levels.

This unit allows the 30 students of the classroom to visualize simultaneously all the results and the manipulation of the unit, during the process, by using a projector or an electronic whiteboard.



④ **Heat Exchangers available** to be used with the Basic Service Base Unit:

④.2 **TICT/SS. Basic Heat Exchanger Casing and Tubes.**

Panel made of painted steel.

Diagram in the front panel with distribution of the elements similar to the real one.

Shell made of PMMA:

Internal diameter: 50 mm.

Thickness = 3 mm.

Tube bundle made of stainless steel:

Internal diameter: 5 mm.

Thickness = 1 mm.

Number of tubes: 7.

Heat transfer area: 0.02 m².

Quick release fittings to connect the exchanger to the service base unit.

This unit is supplied with 8 manuals: Required Services, Assembly and Installation, Interface and Control Software, Starting-up, Safety, Maintenance, Calibration & Practices Manuals.

Computer Control Software:

PID Computer Control + Data Acquisition + Data Management Software for Basic Heat Exchanger Casing and Tubes (TICT/SS).

The three softwares are part of the SCADA system.

Compatible with actual Windows operating systems. Graphic and intuitive simulation of the process in screen. **Compatible with the industry standards.**

Registration and visualization of all process variables in an automatic and simultaneous way.

Flexible, open and multicontrol software, developed with actual windows graphic systems, acting simultaneously on all process parameters.

Analog and digital PID control.

PID menu and set point selection required in the whole work range.

Management, processing, comparison and storage of data.

Sampling velocity up to 250 KS/s (kilo samples per second).

Calibration system for the sensors involved in the process.

It allows the registration of the alarms state and the graphic representation in real time.

Comparative analysis of the obtained data, after the process and modification of the conditions during the process.

Open software, allowing the teacher to modify texts, instructions. Teacher's and student's passwords to facilitate the teacher's control on the student, and allowing the access to different work levels.

This unit allows the 30 students of the classroom to visualize simultaneously all the results and the manipulation of the unit, during the process, by using a projector or an electronic whiteboard.



④ Heat Exchangers available to be used with the Basic Service Base Unit:

④.2 TIVES/SS. Basic Stirred-Tank Heat Exchanger with Double Jacket and Coil.

Panel made of painted steel.

Diagram in the front panel with distribution of the elements similar to the real one.

Tank made of stainless steel with jacket:

Capacity: 1.2 l.

Heat transfer area: 0.05 m².

Computer controlled adjustable speed stirrer, range: 0 – 350 r.p.m.

Coil made of stainless steel:

Heat transfer area: 0.05 m².

Temperature sensor "J" type in the tank.

Quick release fittings to connect the exchanger to the service base unit.

This unit is supplied with 8 manuals: Required Services, Assembly and Installation, Interface and Control Software, Starting-up, Safety, Maintenance, Calibration & Practices Manuals.

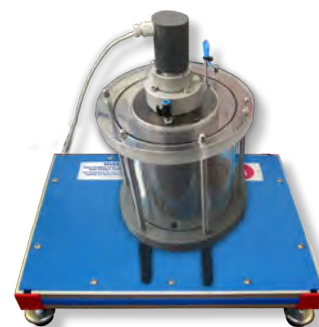

TIVES/SS

Computer Control Software:

PID Computer Control + Data Acquisition + Data Management Software for Basic Stirred-Tank Heat Exchanger with Double Jacket and Coil (TIVES/SS).

The three softwares are part of the SCADA system.

Compatible with actual Windows operating systems. Graphic and intuitive simulation of the process in screen. **Compatible with the industry standards.**

Registration and visualization of all process variables in an automatic and simultaneous way.

Flexible, open and multicontrol software, developed with actual windows graphic systems, acting simultaneously on all process parameters.

Analog and digital PID control.

PID menu and set point selection required in the whole work range.

Management, processing, comparison and storage of data.

Sampling velocity up to 250 KS/s (kilo samples per second).

Calibration system for the sensors involved in the process.

It allows the registration of the alarms state and the graphic representation in real time.

Comparative analysis of the obtained data, after the process and modification of the conditions during the process.

Open software, allowing the teacher to modify texts, instructions. Teacher's and student's passwords to facilitate the teacher's control on the student, and allowing the access to different work levels.

This unit allows the 30 students of the classroom to visualize simultaneously all the results and the manipulation of the unit, during the process, by using a projector or an electronic whiteboard.



⑤ Cables and Accessories, for normal operation.

⑥ Manuals:

This unit is **supplied with 8 manuals**: Required Services, Assembly and Installation, Interface and Control Software, Starting-up, Safety, Maintenance, Calibration & Practices Manuals.

*References 1 to 6 are the main items: TICC/SS + TICC/SS/CIB + DAB + Cables and Accessories + Manuals are included in the minimum supply for enabling normal and full operation.

EXERCISES AND PRACTICAL POSSIBILITIES TO BE DONE WITH THE MAIN ITEMS

Practices to be done with the Basic Concentric Tube Heat Exchanger (TITC/SS):

- 1.- Global energy balance in the heat exchanger and the study of losses.
- 2.- Exchanger effectiveness determination. NTU Method.
- 3.- Study of the heat transfer under counter-current and co-current flow conditions.
- 4.- Flow influence on the heat transfer. Reynolds number calculation.
- 5.- Study of the pressure drop in the exchanger.

Additional practical possibilities:

- 6.- Control system: Temperature sensors calibration.
- 7.- Control system: Flow sensors calibration.
- 8.- Study of the hysteresis of the flow sensor.

Practices to be done with the Basic Plate Heat Exchanger (TIPL/SS):

- 9.- Global energy balance in the heat exchanger and the study of losses.
- 10.-Exchanger effectiveness determination. NTU Method.
- 11.-Study of the heat transfer under counter-current and co-current flow conditions.
- 12.-Flow influence on the heat transfer. Reynolds number calculation.
- 13.-Study of the pressure drop in the exchanger.

Additional practical possibilities:

- 14.-Control system: Temperature sensors calibration.
- 15.-Control system: Flow sensors calibration.
- 16.-Study of the hysteresis of the flow sensor.

Practices to be done with the Basic Shell & Tube Heat Exchanger (TICT/SS):

- 17.-Global energy balance in the heat exchanger and the study of losses.
- 18.-Exchanger effectiveness determination. NTU Method.
- 19.-Study of the heat transfer under counter-current and co-current flow conditions.
- 20.-Flow influence on the heat transfer. Reynolds number calculation.
- 21.-Study of the pressure drop in the exchanger.

Additional practical possibilities:

- 22.-Control system: Temperature sensors calibration.
- 23.-Control system: Flow sensors calibration.
- 24.-Study of the hysteresis of the flow sensor.

Practices to be done with the Basic Stirred-Tank Heat Exchanger with Double Jacket and Coil (TIVES/SS):

- 25.-Global balance of energy in the tank heat exchanger with double jacket and losses study.

26.-Global balance of energy in the the tank heat exchanger with coil and losses study.

- 27.-Determination of the exchanger effectiveness. NTU Method.
- 28.-Influence of the flow on the heat transfer. Calculation of the number of Reynolds.
- 29.-Influence of the vessel stirring on the heat transfer when operating in batches.
- 30.-Influence of the vessel's water volume on the heat transfer when operating in batches.
- 31.-Study of the pressure drop in the exchanger.

Additional practical possibilities:

- 32.-Control system: Temperature sensors calibration.
- 33.-Control system: Flow sensors calibration.
- 34.-Study of the hysteresis of the flow sensor.

Other possibilities to be done with this Unit:

- 35.-Many students view results simultaneously.
To view all results in real time in the classroom by means of a projector or an electronic whiteboard.
- 36.-Open Control, Multicontrol and Real Time Control.
This unit allows intrinsically and/or extrinsically to change the span, gains; proportional, integral, derivative parameters; etc, in real time.
- 37.-The Computer Control System with SCADA and PID Control allow a real industrial simulation.
- 38.-This unit is totally safe as uses mechanical, electrical and electronic, and software safety devices.
- 39.-This unit can be used for doing applied research.
- 40.-This unit can be used for giving training courses to Industries even to other Technical Education Institutions.
- 41.-Control of the TICC/SS unit process through the control interface box without the computer.
- 42.-Visualization of all the sensors values used in the TICC/SS unit process.

- By using PLC-PI additional 19 more exercises can be done.

- Several other exercises can be done and designed by the user.

REQUIRED SERVICES

- Electrical supply: single-phase, 220 V./50Hz or 110V./60 Hz.
- Water supply (0 to 6 l/min approx) or the recommended element "TERA".
- Drainage.
- Computer.

DIMENSIONS AND WEIGHTS

TICC/SS:

TIUS/SS. Base Service Unit:

- Dimensions: 1100 x 700 x 500 mm approx.
(43.30 x 27.55 x 19.68 inches approx.)
- Weight: 50 Kg approx.
(110.2 pounds approx.)

TITC/SS. Unit:

- Dimensions: 500 x 250 x 150 mm approx.
(43.30 x 9.84 x 5.90 inches approx.)
- Weight: 20 Kg approx.
(44.09 pounds approx.)

TIPL/SS. Unit:

- Dimensions: 400 x 250 x 100 mm approx.
(15.74 x 9.84 x 3.93 inches approx.)
- Weight: 20 Kg approx.
(44.09 pounds approx.)

TICT/SS. Unit:

- Dimensions: 400 x 250 x 150 mm approx.
(15.74 x 9.84 x 5.90 inches approx.)
- Weight: 30 Kg approx.
(66.13 pounds approx.)

TIVES/SS. Unit:

- Dimensions: 400 x 250 x 400 mm approx.
(15.74 x 9.84 x 15.74 inches approx.)
- Weight: 35 Kg approx.
(77.16 pounds approx.)

Control Interface Box:

- Dimensions: 490 x 330 x 310 mm approx.
(19.29 x 12.99 x 12.20 inches approx.)
- Weight: 10 Kg approx.
(22 pounds approx.)

OPTIONAL MODELS AND ACCESSORIES

- TITC/SS. Basic Concentric Tube Heat Exchanger.
- TIPL/SS. Basic Plate Heat Exchanger.
- TICT/SS. Basic Shell & Tube Heat Exchanger.
- TIVES/SS. Basic Stirred-Tank Heat Exchanger with Double Jacket and Coil.

RECOMMENDED ELEMENTS (Not Included)

- TERA. Refrigeration Water Recirculation Unit.

COMPLETE TECHNICAL SPECIFICATIONS (for optional items)

Additionally to the main items (1 to 6) described, we can offer, as optional, other items from 7 to 11.

All these items try to give more possibilities for:

- a) Industrial configuration. (PLC)
- b) Technical and Vocational Education configuration. (ICAI and FSS)
- c) Multipost Expansions options. (MINI ESN and ESN)

a) Industrial configuration

⑦ PLC. Industrial Control using PLC (it includes PLC-PI Module plus PLC-SOF Control Software):

-PLC-PI. PLC Module:

Metallic box.

Circuit diagram in the module front panel.

Front panel:

Digital inputs (X) and Digital outputs (Y) block:

16 Digital inputs, activated by switches and 16 LEDs for confirmation (red).

14 Digital outputs (through SCSI connector) with 14 LEDs for message (green).

Analog inputs block:

16 Analog inputs (-10 V. to + 10 V.) (through SCSI connector).

Analog outputs block:

4 Analog outputs (-10 V. to + 10 V.) (through SCSI connector).

Touch screen:

High visibility and multiple functions. Display of a highly visible status. Recipe function. Bar graph function. Flow display function. Alarm list. Multi language function. True type fonts.

Back panel:

Power supply connector. Fuse 2A. RS-232 connector to PC. USB 2.0 connector to PC.

Inside:

Power supply outputs: 24 Vdc, 12 Vdc, -12 Vdc, 12 Vdc variable.

Panasonic PLC:

High-speed scan of 0.32 μ sec. for a basic instruction.

Program capacity of 32 Ksteps, with a sufficient comment area.

Power supply input (100 to 240 V AC).

DC input: 16 (24 V DC).

Relay output: 14.

High-speed counter.

Multi-point PID control.

Digital inputs/outputs and analog inputs/outputs Panasonic modules.

Communication RS232 wire to computer (PC).

Dimensions: 490 x 330 x 310 mm. approx. (19.29 x 12.99 x 12.20 inches approx.). Weight: 30 Kg. approx. (66 pounds approx.).

-TICC/SS/PLC-SOF. PLC Control Software:

For this particular unit, always included with PLC supply.

The software has been designed using Labview and it follows the unit operation procedure and linked with the Control Interface Box used in the Computer Controlled Heat Exchangers Basic Unit (TICC/SS).

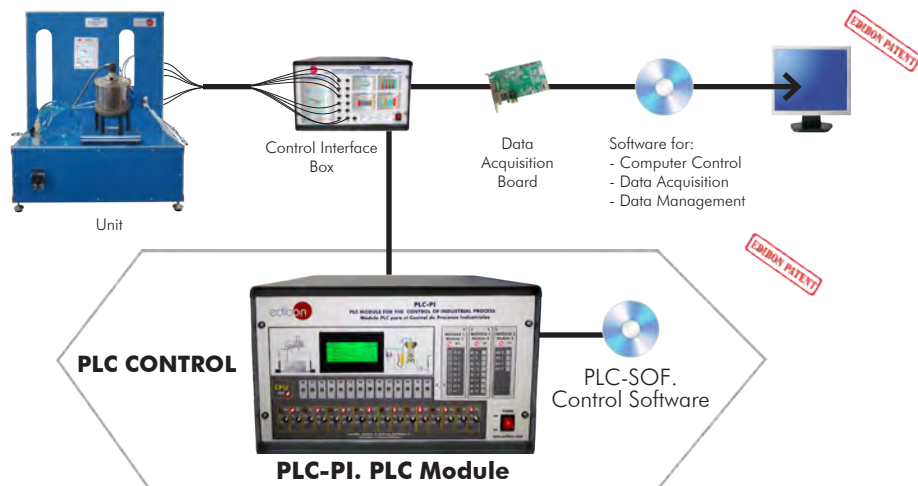

Practices to be done with PLC-PI:

- 1.- Control of the particular unit process through the control interface box without the computer.
- 2.- Visualization of all the sensors values used in the particular unit process.
- 3.- Calibration of all sensors included in the particular unit process.
- 4.- Hand on of all the actuators involved in the particular unit process.
- 5.- Realization of different experiments, in automatic way, without having in front the particular unit. (These experiments can be decided previously).
- 6.- Simulation of outside actions, in the cases do not exist hardware elements. (Example: test of complementary tanks, complementary industrial environment to the process to be studied, etc).
- 7.- PLC hardware general use.
- 8.- PLC process application for the particular unit.
- 9.- PLC structure.
- 10.- PLC inputs and outputs configuration.
- 11.- PLC configuration possibilities.
- 12.- PLC program languages.
- 13.- PLC different programming standard languages (ladder diagram (LD), structured text (ST), instructions list (IL), sequential function chart (SFC), function block diagram (FBD)).
- 14.- New configuration and development of new process.
- 15.- Hand on an established process.
- 16.- To visualize and see the results and to make comparisons with the particular unit process.
- 17.- Possibility of creating new process in relation with the particular unit.
- 18.- PLC Programming Exercises.
- 19.- Own PLC applications in accordance with teacher and student requirements.

b) Technical and Vocational Education configuration

⑧ TICC/SS/ICAI. Interactive Computer Aided Instruction Software System.

This complete software package consists of an Instructor Software (EDIBON Classroom Manager - ECM-SOF) totally integrated with the Student Software (EDIBON Student Labsoft - ESL-SOF). Both are interconnected so that the teacher knows at any moment what is the theoretical and practical knowledge of the students.

This software is optional and can be used additionally to items (1 to 6).

- ECM-SOF. EDIBON Classroom Manager (Instructor Software).

ECM-SOF is the application that allows the Instructor to register students, manage and assign tasks for workgroups, create own content to carry out Practical Exercises, choose one of the evaluation methods to check the Student knowledge and monitor the progression related to the planned tasks for individual students, workgroups, units, etc... so the teacher can know in real time the level of understanding of any student in the classroom.

Innovative features:

- User Data Base Management.
- Administration and assignment of Workgroup, Task and Training sessions.
- Creation and Integration of Practical Exercises and Multimedia Resources.
- Custom Design of Evaluation Methods.
- Creation and assignment of Formulas & Equations.
- Equation System Solver Engine.
- Updatable Contents.
- Report generation, User Progression Monitoring and Statistics.

- ESL-SOF. EDIBON Student Labsoft (Student Software).

ESL-SOF is the application addressed to the Students that helps them to understand theoretical concepts by means of practical exercises and to prove their knowledge and progression by performing tests and calculations in addition to Multimedia Resources. Default planned tasks and an Open workgroup are provided by EDIBON to allow the students start working from the first session. Reports and statistics are available to know their progression at any time, as well as explanations for every exercise to reinforce the theoretically acquired technical knowledge.

Innovative features:

- Student Log-In & Self-Registration.
- Existing Tasks checking & Monitoring.
- Default contents & scheduled tasks available to be used from the first session.
- Practical Exercises accomplishment by following the Manual provided by EDIBON.
- Evaluation Methods to prove your knowledge and progression.
- Test self-correction.
- Calculations computing and plotting.
- Equation System Solver Engine.
- User Monitoring Learning & Printable Reports.
- Multimedia-Supported auxiliary resources.

For more information see ICAI catalogue. Click on the following link:
www.edibon.com/en/files/expansion/ICAI/catalog

Instructor Software

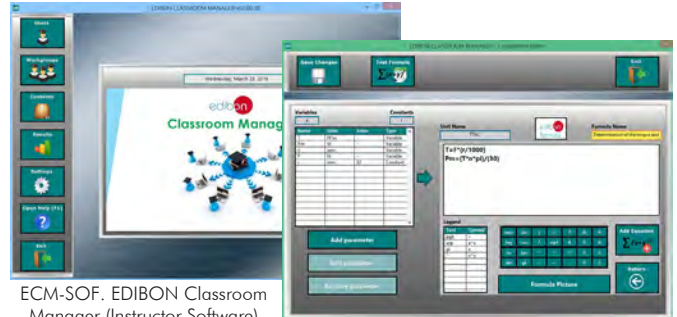

ECM-SOF. EDIBON Classroom Manager (Instructor Software) Application Main Screen

ECAL. EDIBON Calculations Program Package - Formula Editor Screen



ERS. EDIBON Results & Statistics Program Package - Student Scores Histogram

ETTE. EDIBON Training Test & Exam Program Package - Main Screen with Numeric Result Question

Student Software

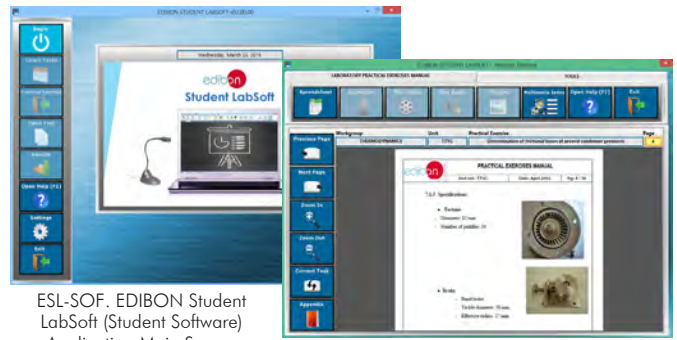

ESL-SOF. EDIBON Student LabSoft (Student Software) Application Main Screen

EPE. EDIBON Practical Exercise Program Package Main Screen

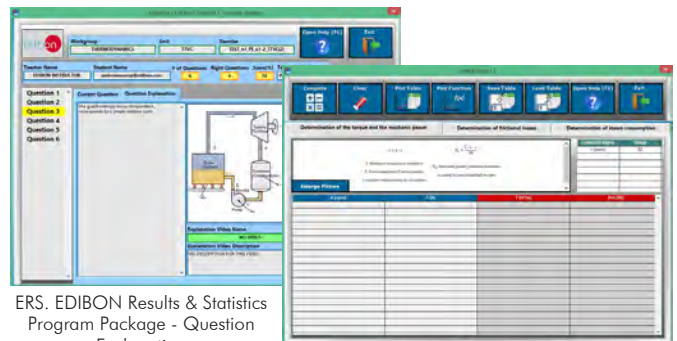

ERS. EDIBON Results & Statistics Program Package - Question Explanation

ECAL. EDIBON Calculations Program Package Main Screen

⑨ **TICC/SS/FSS. Faults Simulation System.**

Faults Simulation System (FSS) is a Software package that simulates several faults in any EDIBON Computer Controlled Unit. It is useful for Technical and Vocational level.

The "FAULTS" mode consists in causing several faults in the unit normal operation. The student must find them and solve them. There are several kinds of faults that can be grouped in the following sections:

- Faults affecting the sensors measurement:
 - An incorrect calibration is applied to them.
 - Non-linearity.
- Faults affecting the actuators:
 - Actuators channels interchange at any time during the program execution.
 - Response reduction of an actuator.
- Faults in the controls execution:
 - Inversion of the performance in ON/OFF controls.
 - Reduction or increase of the calculated total response.
 - The action of some controls is annulled.
- On/off faults:
 - Several on/off faults can be included.

Example of some screens

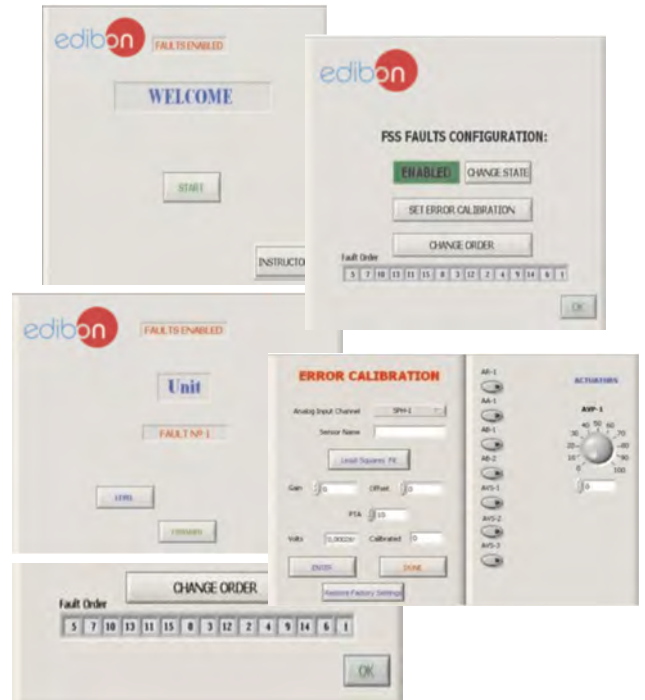

For more information see FSS catalogue. Click on the following link:

www.edibon.com/en/files/expansion/FSS/catalog

c) Multipost Expansions options

⑩ **MINI ESN. EDIBON Mini Scada-Net System for being used with EDIBON Teaching Units.**

MINI ESN. EDIBON Mini Scada-Net System allows up to 30 students to work with a Teaching Unit in any laboratory, simultaneously. It is useful for both, Higher Education and/or Technical and Vocational Education.

The MINI ESN system consists of the adaptation of any EDIBON Computer Controlled Unit with SCADA and PID Control integrated in a local network.

This system allows to view/control the unit remotely, from any computer integrated in the local net (in the classroom), through the main computer connected to the unit. Then, the number of possible users who can work with the same unit is higher than in an usual way of working (usually only one).

Main characteristics:

- It allows up to 30 students to work simultaneously with the EDIBON Computer Controlled Unit with SCADA and PID Control, connected in a local net.
- Open Control + Multicontrol + Real Time Control + Multi Student Post.
- Instructor controls and explains to all students at the same time.
- Any user/student can work doing "real time" control/multicontrol and visualisation.
- Instructor can see in the computer what any user/student is doing in the unit.
- Continuous communication between the instructor and all the users/students connected.

Main advantages:

- It allows an easier and quicker understanding.
- This system allows you can save time and cost.
- Future expansions with more EDIBON Units.

For more information see MINI ESN catalogue. Click on the following link:

www.edibon.com/en/files/expansion/MINI-ESN/catalog

⑪ **ESN. EDIBON Scada-Net Systems.**

This unit can be integrated, in the future, into a Complete Laboratory with many Units and many Students.

For more information see ESN catalogue. Click on the following link:

www.edibon.com/en/files/expansion/ESN/catalog

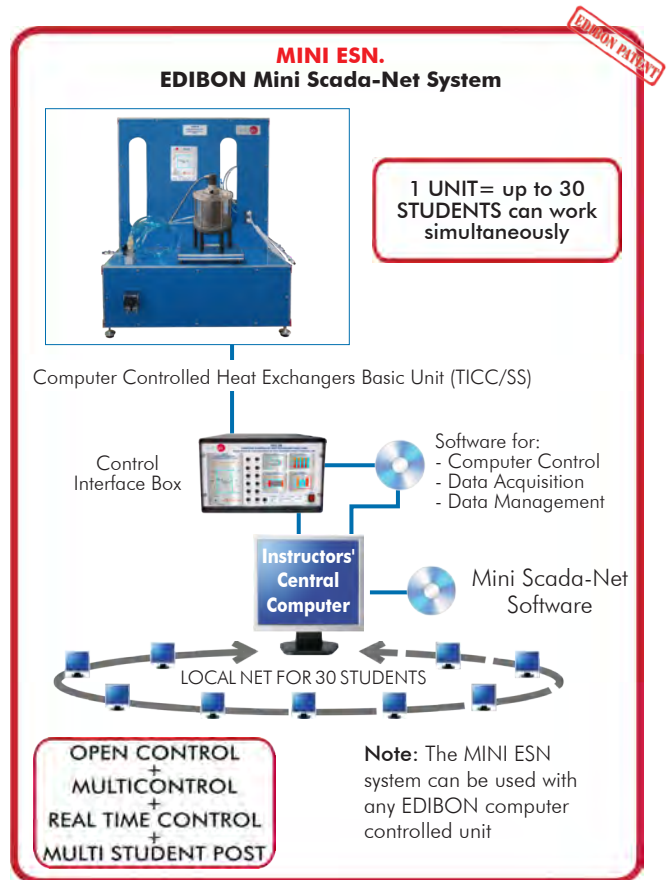

ORDER INFORMATION

Main items (always included in the supply)

Common items for Heat Exchangers type "TI":

- ① **TIUS/SS. Basic Service Base Unit. (Common for Heat Exchangers type "TI" and can work with one or several exchangers).**
- ② **TICC/SS/CIB. Control Interface Box. (Common for Heat Exchangers type "TI" and can work with one or several exchangers).**
- ③ **DAB. Data Acquisition Board. (Common for Heat Exchangers type "TI").**
 - ④ Heat Exchangers available to be used with the Base Basic Service Unit
- ④.1 **TITC/SS. Basic Concentric Tube Heat Exchanger, and / or**
- ④.2 **TIPL/SS. Basic Plate Heat Exchanger, and / or**
- ④.3 **TICT/SS. Basic Shell & Tube Heat Exchanger, and / or**
- ④.4 **TIVES/SS. Basic Stirred-Tank Heat Exchanger with Double Jacket and Coil, and / or.**
- ⑤ **Cables and Accessories, for normal operation.**
- ⑥ **Manuals.**

***IMPORTANT:** Under TICC/SS we always supply all the elements for immediate running as 1, 2, 3, 4, 5 and 6.

Optional items (supplied under specific order)

a) Industrial configuration

- ⑦ **PLC. Industrial Control using PLC (it includes PLC-PI Module plus PLC-SOF Control Software):**
 - PCL-PI. PLC Module.
 - TICC/SS/PLC-SOF. PLC Control Software.

b) Technical and Vocational Education configuration

- ⑧ **TICC/SS/ICAL. Interactive Computer Aided Instruction Software System.**
- ⑨ **TICC/SS/FSS. Faults Simulation System.**

c) Multipost Expansions options

- ⑩ **MINI ESN. EDIBON Mini Scada-Net System for being used with EDIBON Teaching Units.**
- ⑪ **ESN. EDIBON Scada-Net Systems.**

* Specifications subject to change without previous notice, due to the convenience of improvement of the product.



C/ Julio Cervera, 10-12-14. Móstoles Tecnológico.
28935 MÓSTOLES. (Madrid). ESPAÑA - SPAIN.
Tel.: 34-91-6199363 Fax: 34-91-6198647

E-mail: edibon@edibon.com Web: www.edibon.com

Edition: ED01/18
Date: April/2018

REPRESENTATIVE: