

www.edibon.com
 ↳ Products
 ↳ Products range
 ↳ Units
 ↳ 13.-Environment



EFAS. Unit

- Detail of the accessories included:
- Rectangular model for a lake construction.
 - Rectangular model for an excavation construction.
 - Cylindrical model for a confined aquifer construction.



Detail of tank inside (pressure tappings, wells, etc)



Detail of tank inside with sand



ISO 9000: Quality Management
 (for Design, Manufacturing,
 Commercialization and After-sales service)



European Union Certificate
 (total safety)



**Certificates ISO 14000 and
 ECO-Management and Audit Scheme**
 (environmental management)



**Worlddidac Quality Charter
 Certificate**
 (Worlddidac Member)

DESCRIPTION

Unit for demonstrating the hydrological principles of groundwater flow and the applications of these to different engineering constructions. It allows the investigation of ground water flows, the drainage processes and the effect of the permeability.

It is possible to study the use of wells, de-watering and drainage of lakes, and demonstration of ground drainage works, among others.

This unit allows a quick configuration of any easy situation of tridimensional flow and to measurement the piezometric levels at different and appropriate places within the model, making possible to obtain realistic experimental results.

The Ground Water Flow Unit (EFAS) is composed of a test tank that will be filled with fine gravel or sand to construct to develop different models. The entry of water into the tank is done through two inlets, each of them located at each end. The flow of each water inlet is controlled by a membrane valve, which is easily accessible for the user. Inlets end inside the tank in a diffuser shape to affect the least possible the created model.

In the base of the test tank there are two wells symmetrically located. The wells outlets, located at the bottom part of the tank, have a membrane valve, that allows the regulation of the outlet flows. Wells have a spillway in their upper part to avoid floods.

The unit includes 19 tapings in the base of the test tank, configured in cross shape. Pressure of the 19 tapings can be seen in 2 manometers panels. The tapings have a sediments picking system to avoid them to reach the measuring elements. Under each tapping there is a plug which has to be removed regularly to extract the sand accumulated in it.

EFAS unit is supplied with three accessories that make it easy the construction of the different models object of study:

1. - Model for a lake construction.
2. - Model for an excavation construction.
3. - Model for a confined aquifer construction.

In addition to the demonstrations and exercises proposed (see "Exercises and Practical Possibilities" section), instructors and students may construct further model situations for study.

PROCESS DIAGRAM AND UNIT ELEMENTS ALLOCATION

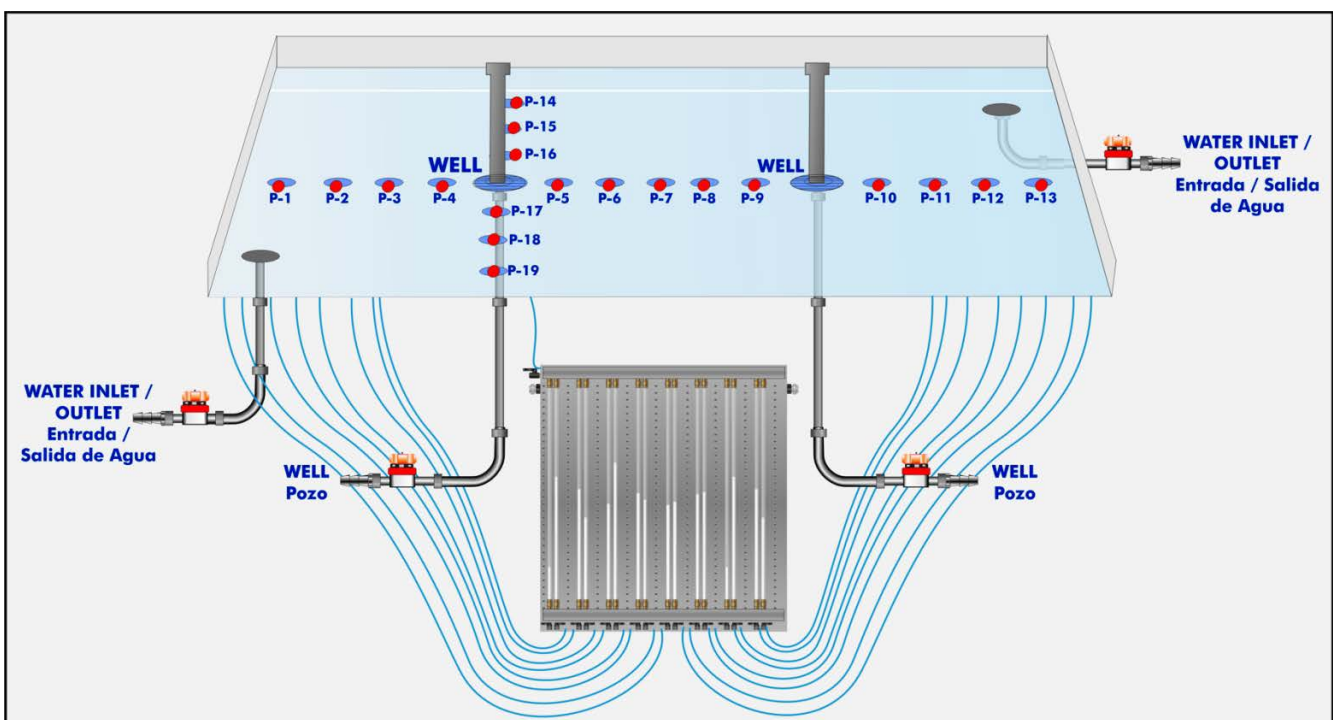

Note: P= Pressure tapping.

SPECIFICATIONS

Unit mounted on anodized aluminium profiles and painted steel panels.

Diagram in the front panel with similar distribution to the elements in the real unit.

A test tank, made in fibreglass reinforced polyester, 1000 mm of length x 500 mm of width and 240 mm of depth.

Two membrane valves to regulate water inlet flows to the test tank.

Two wells symmetrically located in the test tank.

Two membrane valves to regulate water outlet flows from the wells.

19 tapings to measure the hydraulic gradients, connected to column water manometers of 300 mm. long. The manometers have individual ball valves to purge the tubes.

Air manual pump connected to the manometers.

Three accessories that make it easy the construction of the different models object of study:

- 1.-Rectangular model for a lake construction.
- 2.-Rectangular model for an excavation construction.
- 3.-Cylindrical model for a confined aquifer construction.

Flexible pipes and quick connectors.

This unit incorporates wheels for its mobility.

Manuals:

This unit is supplied with the following manuals: Required Services, Assembly and Installation, Starting-up, Safety, Maintenance & Practices Manuals.

EXERCISES AND PRACTICAL POSSIBILITIES

Some Practical Possibilities of the Unit:

- 1.- Demonstration of hydraulic gradients in ground water flow, including the effect of permeability.
- 2.- Investigation of hydraulic gradients for different models built on the test tank.
- 3.- Determination of the ground water level between inlet and outlet.
- 4.- Demonstration of the Darcy's Law.
- 5.- Study of the cone of depression for a well in a confined aquifer.
- 6.- Study of the cone of depression for a well in a free aquifer.
- 7.- Study of the cone of depression cone for two wells.
- 8.- Experiment to obtain hydraulic gradients for a model with two wells. Compare it with the result of only one well by the superposition method.
- 9.- Draining of or lake model.
- 10.- De-watering of an excavation model under freatic level.
- 11.- De-watering of an excavation model using two wells.
- 12.- Interaction of cones of depression by two adjoining wells.
- 13.- Draw-down curves for one well and two wells systems.
- 14.- Comparison of different profiles, combinations.
- 15.- How to fill the manometer tubes.

REQUIRED SERVICES

- Water Supply, or Basic Hydraulic Feed System "FME00/B", or Hydraulic Bench "FME00".

FME00/B specifications:

Centrifugal pump: 0.37 KW, 30 - 80 l/min, at 20.1-12.8m., single-phase 220V. / 50Hz. or 110V. / 60Hz.

Tank capacity: 140 litres approx.

Flowmeter.

Membrane type flow adjusting valve.

This unit incorporates wheels for mobility.

FME00 specifications:

Mobile hydraulic bench, made in fibreglass reinforced polyester, and mounted on wheels for its mobility.

Centrifugal pump, 0.37 KW, 30 - 80 l/min, at 20.1-12.8 m., single-phase 220V. / 50Hz or 110V. / 60Hz.

Sump tank capacity: 165 litres.

Small channel: 8 litres.

Flow measurement: volumetric tank, gauged from 0 to 7 litres for low flow values and from 0 to 40 litres for high flow values.

Control valve for regulating the flow.

Measuring cylinder is provided for the measurement of small flow rates.

Remote hand-operating dump valve in the base of the volumetric tank.

- Drain for water.
- Fine gravel or sand for the test tank.

DIMENSIONS & WEIGHTS

- Dimensions: 1100 x 650 x 1400 mm. approx.
- Weight: 100 Kg. approx.

* Specifications subject to change without previous notice, due to the convenience of improvements of the product.



C/ Del Agua, 14. Polígono Industrial San José de Valderas.
28918 LEGANÉS. (Madrid). SPAIN.
Phone: 34-91-6199363 FAX: 34-91-6198647
E-mail: edibon@edibon.com WEB site: www.edibon.com

Issue: ED02/11
Date: October/2011

REPRESENTATIVE: