

EXPANSIONS INCLUDED
FREE OF CHARGE



ELK



ICAI

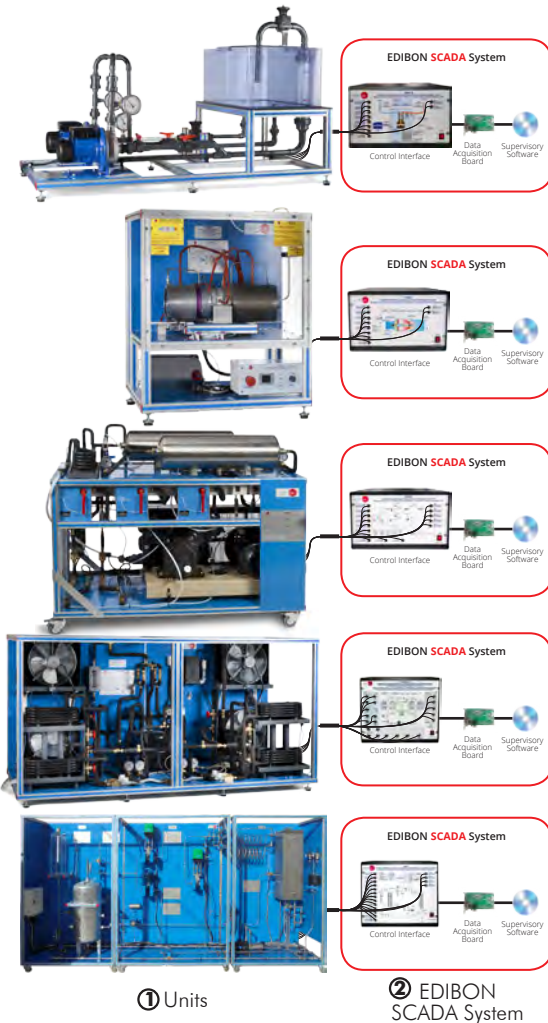

EDIBON SCADA System with NI CompactRIO

- ✓ Advanced Monitor and Supervisor Platform
- ✓ Programmable Real Time Control Architecture
- ✓ Precisely and Truthfully Timed Data Acquisition



③ EDIBON
CompactRIO
Interface



④ NI CompactRIO



⑤ Computer
(not included in
the supply)

Application: CompactRIO can be used with
ALL EDIBON units using SCADA. See www.edibon.com

Key features:

- Introduction to programming in a practical way with EDIBON TECHNICAL TEACHING EQUIPMENT. Real hardware development environment using NI LabVIEW™ at engineering R&D level.
- Open Source Software packages (OSS).
- Ideal for Industry 4.0, Internet of Things, monitoring and control applications.
- Modular architecture, embedded control and data acquisition.
- Capable of doing applied research, real industrial simulation, training courses, etc.
- Remote control of the equipment by the user and EDIBON technical support, allowing to carry out the practical exercises from anywhere.
- Rugged, reliable, industrial embedded controller with industry-standard certifications.
- Linux Real Time OS is run by the embedded processor, ensuring higher reliability.
- High-performance programmable FPGA with customizable hardware, tight synchronization and inline signal processing.
- Deterministic and low-latency response.
- High-performance processing capabilities both in CPU and FPGA.
- Accurate and synchronized measurements.
- Industrial I/O Modules with integrated signal conditioning.
- Autonomous and distributed operation.



ISO 9001: Quality Management (for Design, Manufacturing, Commercialization and After-sales service)



European Union Certificate
(total safety)



Certificates ISO 14001 and ECO-Management and Audit Scheme (environmental management)



"Worlddidac Quality Charter" and Platinum Member of Worlddidac

INTRODUCTION

Most industrial and machine systems typically include an HMI (Human Machine Interface) and a real-time control system. Real-time controllers offer reliable and predictable machine behavior, while HMIs provide the machine operator a graphical user interface to monitor the state of the machine and set the operating parameters.

Controllers based on PLC or PAC are used in typical machine control systems.

National Instruments (NI) controllers are the main component for reconfigurable embedded systems known as NI CompactRIO System. They are rugged and embedded systems composed of a controller with a processor and user-programmable FPGA and several I/O industrial modules, which provide direct access to sensors and advanced functions.



GENERAL DESCRIPTION

Generally, PLC controllers include functionalities such as analog and digital I/O, a memory table to share I/O and variable values, and a set of sequential instructions that define the machine behavior.

In addition to these PLC capabilities, National Instruments CompactRIO systems can provide more sophisticated functionalities:

- High-speed data acquisition and analysis.
- Motion control, vision and inspection.
- Signal processing based on custom hardware.
- Intelligent Data logging and embedded complex mathematics.
- Etc.

EDIBON Industrial Modular System with NI CompactRIO contains three components: a real time controller, a reconfigurable field-programmable gate array (FPGA) an industrial I/O modules.

The real-time controller contains an industrial processor that reliably and deterministically executes LabVIEW Real-Time applications and offers multiplate sampling control, execution tracing, integrated data logging, and communication with peripherals.

The reconfigurable FPGA inside the chassis is the center of the embedded system architecture. The reconfigurable I/O (RIO) modules of the FPGA are directly connected to the I/O modules for high-performance access to the I/O circuits of each module and unlimited timing and triggering and flexible synchronization.

I/O modules include insulation, conversion circuits, signal conditioning and built-in connectivity for direct connection to industrial sensors/actuators.

In addition to this, with **EDIBON Software Development and Research KIT (design your own algorithm), "ELK"**, users can get started in the fields of instruments and hardware control and programming. Researchers can work without limits with any value and parameter, control the data acquisition and its subsequent processing and change the control algorithms.

The readings of sensors and calculated values can be viewed in real time and the hardware elements, such as valves, pumps, turbines, etc., can be controlled. Also a ICAI and ELK licenses are included free of charge.

COMPLETE TECHNICAL SPECIFICATIONS (for ECR Expansion item)

The EDIBON Industrial Modular System with NI CompactRIO, "ECR", software package includes the following items:

- ECR expansion item: 1.
- ELK expansion items included free of charge: 2 and 3.
- ICAI expansion items included free of charge: 4, 5, 6, 7 and 8.

Let us describe first the ECR expansion item (1):

1. ECR-UNIT. EDIBON Industrial Modular System with NI CompactRIO for each EDIBON UNIT

Note: EDIBON designs for each UNIT its own expansion.

The system is composed of a real time controller, a field programmable gate array and industrial I/O modules. A SCADA application is provided to control the processes and read values from sensors under Real Time operating system.

NI CompactRIO Modular System*:

The NI CompactRIO platform is part of the SCADA system. High performance embedded controller with industrial I/O modules, extreme robustness, industry standards certifications, industrial communications and human-machine interface (HMI) functionalities.



INTEGRATED CONTROLLER AND CHASSIS

MODEL	DESCRIPTION	
<p>NI cRIO-9063 667 MHz Dual-Core CPU, 256 MB DRAM, 512 MB Storage, Zynq-7020 FPGA, 4-Slot CompactRIO Controller.</p>	<p>The cRIO-9063 is an embedded controller ideal for advanced control and monitoring applications. An FPGA and a real-time processor run the NI Linux Real Time OS. This rugged controller offers a variety of connectivity ports, including one Gigabit Ethernet, one USB host, one USB device, and a serial one.</p>	

MODULES

MODEL	DESCRIPTION	
<p>NI 9209 with Dsub ±10V, 500 S/s, 16-Channel Voltage Input Module.</p>	<p>The NI-9209 performs single-ended or differential analog input. This module provides 60 VDC CAT I isolation and built-in 50/60 Hz filtering.</p>	
<p>NI 9263 with Spring Terminals 100 kS/s/ch Simultaneous, 16-Bit, ±10 V, 4-Channel Voltage Output Module.</p>	<p>The NI-9263 is a simultaneous updating analog output module. It features overvoltage protection, short-circuit protection, low crosstalk, fast slew rate, high relative accuracy and channel-to-earth ground double isolation barrier.</p>	
<p>NI 9403 with DSub ±10V, 500 S/s, 16-Channel Voltage Input Module.</p>	<p>The NI-9403 is a configurable digital I/O interface for input or output with shift-on-the-fly capabilities. Each channel features transient isolation between the I/O channels and the backplane.</p>	

* Contact EDIBON for other EDIBON SCADA System with NI CompactRIO configurations.

CONFIGURATION EXAMPLE (for ECR expansion)

Configuration example of a EDIBON Industrial Modular System with NI CompactRIO, "ECR" with:

- 1 ECR-EG5C
- 1 ELK
- 1 ICAI

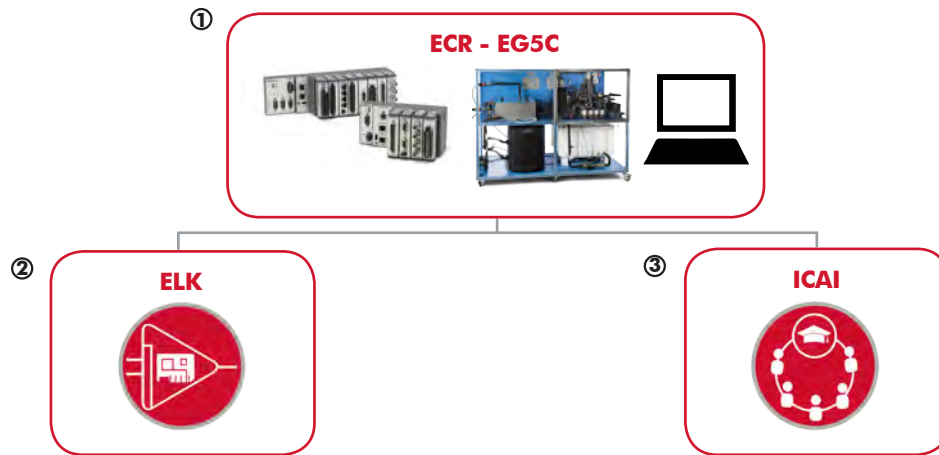

① ECR-EG5C. EDIBON Industrial Modular System with NI CompactRIO for EG5C.

② ELK. EDIBON Software Development KIT, Powered by NI LabVIEW™.

③ ICAI. Interactive Computer Aided Instruction Software.

EXERCISES AND PRACTICAL POSSIBILITIES

- 1.- Any practical exercise related to EDIBON units.
- 2.- Practical exercises related to embedded control and monitoring (Edge monitoring).
- 3.- Practical exercises related to synchronized and deterministic communications.
- 4.- Practical exercises related to customizable hardware (user-programmable FPGA, "Hardware in the loop").
- 5.- Practical exercises related to real-time control and measurement (PID and other control strategies, "Adaptative Control").
- 6.- Practical exercises related to industrial communications (EtherCAT, Ethernet/IP, Modbus, PROFIBUS, etc.)
- 7.- Practical exercises related to high performance processing.
- 8.- Practical exercises related to acquisition and analysis of signals.
- 9.- Practical exercises related to vision and control algorithms.
- 10.- Practical exercises related to sensors calibration.
- 11.- Practical exercises related to preventive maintenance.
- 12.- Practical exercises related to machine learning.
- 13.- Practical exercises related to digital twin.

REQUIRED SERVICES

- Electrical supply: single-phase, 220 V/50 Hz or 110 V/60 Hz.
- Computer.

DIMENSIONS AND WEIGHTS

NI CompacRIO Controller and Chassis:

- Dimensions: 178.1 x 87.3 x 64.3 mm approx. (7.01 x 3.44 x 2.63 inches approx.).
- Weight: 683 g approx. (24 oz approx.).

About 1,000 EDIBON units using SCADA, can use the EDIBON Industrial Modular System with NI CompactRIO, "ECR", in the following areas:

1. PHYSICS
2. ELECTRONICS
3. COMMUNICATIONS
4. ELECTRICITY
5. ENERGY
6. MECHATRONICS, AUTOMATION & COMPUMECHATRONICS
7. MECHANICS
8. FLUID MECHANICS
9. THERMODYNAMICS & THERMOTECHNICS
10. PROCESS CONTROL
11. CHEMICAL ENGINEERING
12. FOOD & WATER TECHNOLOGIES
13. ENVIRONMENT
14. BIOMEDICAL ENGINEERING

COMPLETE TECHNICAL SPECIFICATIONS

(for ELK expansion items, license included free of charge)

Additionally to the ECR item (1) described, we include free of charge in the software package, a ELK license: items from 2 to 3.

2. ELK-VI-UNIT. EDIBON LabVIEW Kit Virtual Instrument files for each EDIBON UNIT

Note: EDIBON designs for each UNIT its own expansion.

LabVIEW programs are called virtual instruments, or VIs. They are similar to a functions or subroutines in other programming languages. Those files contain a comprehensive set of tools for acquiring, analyzing, displaying, and storing data, from the processes and experiments.

3. ELK-UNIT. EDIBON LabVIEW Kit for each EDIBON UNIT

Note: EDIBON designs for each UNIT its own expansion.

It's a Software Development Kit base on NI LabVIEW. Acquisitions and Control programs related to the purchased UNIT are provided to monitor processes. Also, a complete open source SCADA application is included to design new Control algorithm or design new user interfaces.

CONFIGURATION EXAMPLE

(for ELK expansion, license included free of charge)

Configuration example of a EDIBON Software Development KIT, Powered by NI LabVIEW™, "ELK" with:

- 1 ELK-EG5C.
- 5 students.
- 1 Virtual Instrument Files.

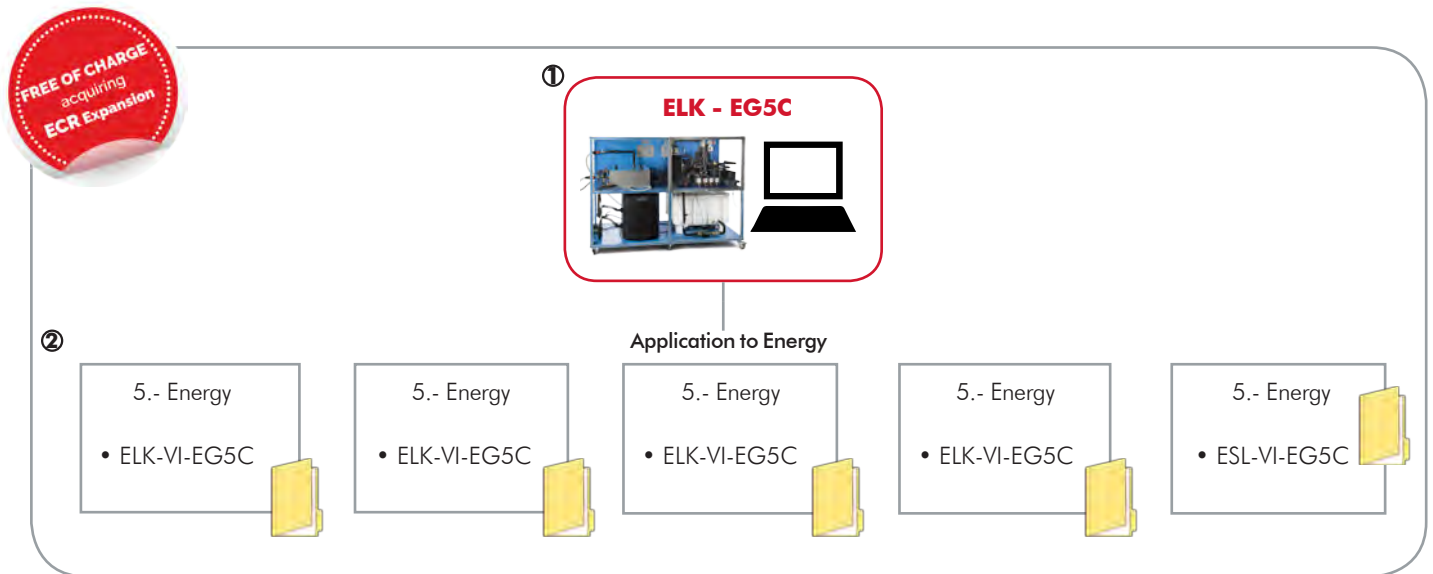

① ELK-EG5C. EDIBON Labview KIT for EG5C

② 5 EDIBON LabVIEW Kit Virtual Instrument files for ELK-VI-EG5C

Additionally to the ECR item (1) and to the ELK items (2 to 3) described, also, we include free of charge in the software package, a ICAI license: items from 4 to 8.

4. ECM-SOF. EDIBON Classroom Manager (Instructor Software)

EDIBON Classroom Manager, "ECM-SOF", is the application that allows the Instructor to register students, manage and assign tasks for workgroups, create own content to carry out Practical Exercises, choose one of the evaluation methods to check the Student knowledge and monitor the progression related to the planned tasks for individual students, workgroups, units, etc... so the teacher can know in real time the level of understanding of any student in the classroom.

5. ESL-SOF. EDIBON Student Labsoft (Student Software)

EDIBON Student Labsoft, "ESL-SOF", is the application addressed to the Students that helps them to understand theoretical concepts by means of practical exercises and to prove their knowledge and progression by performing tests and calculations in addition to Multimedia Resources. Default planned tasks and an Open workgroup are provided by EDIBON to allow the students start working from the first session. Reports and statistics are available to know their progression at any time, as well as explanations for every exercise to reinforce the theoretically acquired technical knowledge.

6. ESL-ECR-SOF. EDIBON E-Learning Content for ECR

EDIBON E-Learning content, "ESL-ECR-SOF", is a set of digital resources created by EDIBON that accompanies each Technical Didactic Team. The resources can be edited or enriched by the instructor adding others if deems it convenient. The content provided by EDIBON includes a practical manual, evaluation exercises, equations and multimedia support material to assimilate the concepts studied with the units.

7. ESL-ELK-SOF. EDIBON E-Learning Content for ELK

EDIBON E-Learning content, "ESL-ELK-SOF", is a set of digital resources created by EDIBON that accompanies each Technical Didactic Team. The resources can be edited or enriched by the instructor adding others if deems it convenient. The content provided by EDIBON includes a practical manual, evaluation exercises, equations and multimedia support material to assimilate the concepts studied with the units.

8. ESL-UNIT-SOF. EDIBON Student Labsoft (Student Software) for each EDIBON UNIT

Note: EDIBON designs for each *UNIT* its own expansion.

EDIBON E-Learning content, "ESL-UNIT-SOF", is a set of digital resources created by EDIBON that accompanies each Technical Teaching Unit. The resources can be edited or enriched by the instructor adding others if deems it convenient. The content provided by EDIBON includes a practical manual, evaluation exercises, equations and multimedia support material to assimilate the concepts studied with the units.

CONFIGURATION EXAMPLE
(for ICAI expansion, license included free of charge)

Configuration example of a Interactive Computer Aided Instruction Software Laboratory, "ICAI", with:

- 1 instructor.
- 5 students.
- 3 E-Learning contents.

Laboratory 1

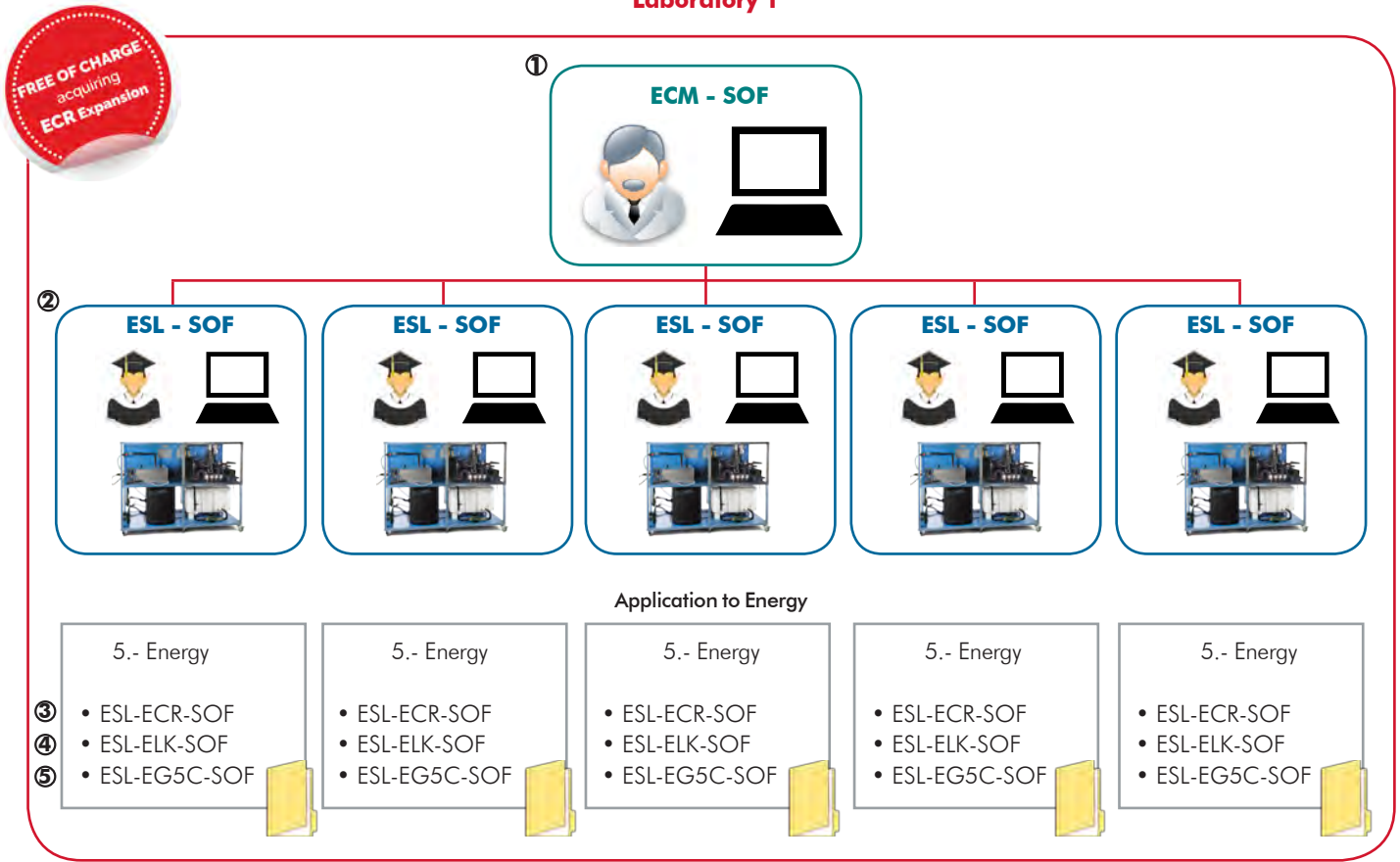

EXAMPLE OF ORDER INFORMATION FOR LABORATORY 1

- | | |
|---|---|
| ① 1 ECM-SOF. INSTRUCTOR SOFTWARE. EDIBON Classroom Manager. | ④ 1 EDIBON E-Learning Content for ELK. |
| ② 5 ESL-SOF. STUDENT SOFTWARE. EDIBON Student Labsoft. | ⑤ 1 EDIBON E-Learning content for ESL-EG5C-SOF. |
| ③ 1 EDIBON E-Learning Content for ECR. | |

The Interactive Computer Aided Instruction Software, "ICAI", in addition to all its features and advantages, allows the use:

- a) Through E-learning mode.
- b) Through the Distance Learning mode in the use of manual units.
- c) Technical Distance Learning, "ECL. EDIBON CLOUD LEARNING", in the case of the use of an EDIBON unit with SCADA and/or with all EXPANSIONS of each EDIBON SCADA.

* Specifications subject to change without previous notice, due to the convenience of improvement of the product.



C/ Julio Cervera, 10-12-14. Móstoles Tecnológico.
28935 MÓSTOLES. (Madrid). ESPAÑA - SPAIN.
Tel.: 34-91-6199363 Fax: 34-91-6198647
E-mail: edibon@edibon.com Web: www.edibon.com

Edition: ED01/20
Date: October/2020

REPRESENTATIVE: